

Cast Steel Flanged Check Valve ANSI 150

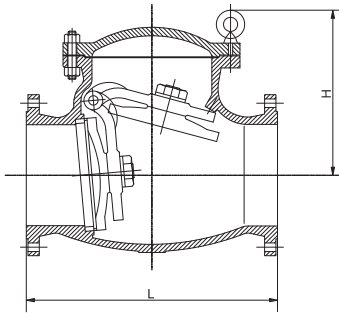

Material List	
PART	MATERIAL
Body	WCB (ASTM A216)
Bonnet	WCB (ASTM A216)
Disc	410 (2Cr13)
Seat	H/F Stellite
Gasket	Graphite

Specifications	
Design	ANSI B16.34
Flange	ANSI B16.5
MAX Working Temperature	300°C
Cold Working Pressure	1960kPa

Cast Steel Flanged Check Valve ANSI 150						
AAP CODE	IMPERIAL SIZE	L	H	HOLE DIAMETER	NO. HOLES	APPROX. KG/PC
VSC15050	2	203.2	135	20	4	19
VSC15065	2 1/2	215.9	147	20	4	26
VSC15080	3	241.3	178	20	4	31
VSC15094	4	292.1	222	20	8	51
VSC15096	6	355.6	314	22	8	85
VSC15098	8	495.6	350	22	8	148
VSC150X25	10	622.3	406	26	12	218
VSC150X30	12	698.3	445	26	12	345

Cast Steel Flanged Check Valve ANSI 300

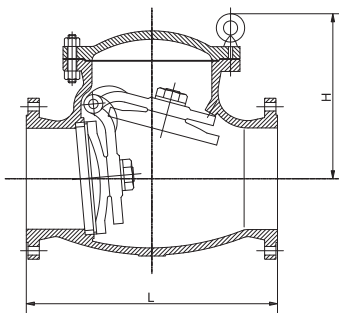

Material List	
PART	MATERIAL
Body	WCB (ASTM A216)
Bonnet	WCB (ASTM A216)
Disc	410 (2Cr13)
Seat	H/F Stellite
Gasket	Graphite

Specifications	
Design	ANSI B16.34
Flange	ANSI B16.5
MAX Working Temperature	440°C
Cold Working Pressure	5100kPa

Cast Steel Flanged Check Valve ANSI 300						
AAP CODE	IMPERIAL SIZE	L	H	HOLE DIAMETER	NO. HOLES	APPROX. KG/PC
VSC30050	2	266.7	160	8	20	25
VSC30080	3	317.5	189	8	22	44
VSC30094	4	355.6	210	8	22	68
VSC30098	8	533.4	418	12	26	197